

MODEL	BF-V220-60
Standby Power (60Hz)	200KW / 250KVA
Prime Power (60Hz)	181KW / 226KVA

Standard Features

General Features:

- Engine (VOLVO TAD733GE)
- Radiator 55°C max, fans are driven by belt, with safety guard
- 24V charge alternator
- Alternator: single bearing alternator IP23, insulation class H/H
- Absorber
- Dry type air filter, fuel filter, oil filter, pre-filter
- Main line circuit breaker
- Standard control panel
- Oil drain pump
- Two 12V batteries, rack and cable
- Ripple flex exhaust pipe, exhaust siphon, flange, muffler
- User manual



PHOTO FOR REFERENCE ONLY

Generator Ratings

Voltage	HZ	Phase	P.F (COS ϕ)	Standby Amps	Standby Ratings (KW/KVA)	Prime Ratings (KW/KVA)
480/277	60	3	0.8	300	200/250	181/226
460/266	60	3	0.8	313	200/250	181/226
440/254	60	3	0.8	328	200/250	181/226
416/240	60	3	0.8	346	200/250	181/226

Prime Power (PRP): Prime power is available for an unlimited number of annual hours in variable load application, in accordance with GB/T2820-97 (eqv ISO8528) ; A 10% overload capability is available for a period of 1 hour within a 12-hour period of operation.

Standby Power Rating (ESP): The standby power rating is applicable for supplying emergency power for the duration of a utility power interruption. No overload, utility parallel or negotiated outage operation capability is available at this rating.

Sales Promises

Baifa Power provides a full line of brand new and high quality products. Each and every unit is strictly factory tested.

Warranty is according to our standard conditions: a, 15 months, counted on the day BAIFA sold to the first buyer; b, One year after installation; c, 1000 running hours (accumulated); subject to the earlier one.

Service and parts are available from Baifa Power or distributors in your location.

ENGINE DATA

Manufacturer / Model:	VOLVO TAD733GE, 4-cycle
Air Intake System:	Turbo, Air/Air Cooling
Fuel System:	Directly Injection Fuel System, Bosch Pump
Cylinder Arrangement:	6 in line
Displacement:	7.15L
Bore and Stroke:	108*130 (mm)
Compression Ratio:	18.1
Rated RPM:	1800rpm
Max. Standby Power at Rated RPM:	218KW/296HP (with fan)
Governor Type:	EDC4

Exhaust System

Exhaust Gas Flow:	44.4m ³ /min
Exhaust Temperature:	530°C
Max Back Pressure:	3kPa

Air Intake System

Max Intake Restriction:	3.5kPa
Burning Capacity:	15.76m ³ /min
Air Flow:	270m ³ /min

Fuel System

100%(Prime Power) Load:	222 g/KWh
75%(Prime Power) Load:	220 g/KWh
50%(Prime Power) Load:	222 g/KWh
Total Fuel Flow:	450L/h

Oil System

Total Oil Capacity:	34L
Oil Consumption:	0.11L/h
Engine Oil Tank Capacity:	31L
Oil Pressure at Rated RPM:	520kPa

Cooling System

Total Coolant Capacity:	37.1L
Thermostat:	87-102°C
Max Water Temperature:	105°C

ALTERNATOR SPECIFICATION

GENERAL DATA

Compliance with GB755, BS5000, VDE0530, NEMAMG1-22, IED34-1, CSA22.2 and AS1359 standards.

Alternator Data

Number of Phase:	3
Connecting Type:	3 Phase and 4 Wires, "Y" type connecting
Number of Bearing:	1
Power Factor:	0.8
Protection Grade:	IP23
Altitude:	≤1000m
Exciter Type:	Brushless, self-exciting
Insulation Class, Temperature Rise:	H/H
Telephone Influence Factor (TIF):	<50
THF:	<2%
Voltage Regulation, Steady State:	±1%
Alternator Capacity:	230KVA
Alternator Efficiencies:	93.2%
Air Cooling Flow:	0.617m ³ /s

GENERATING SET DATA

Voltage Regulation:	±5%
Voltage Regulation, Stead State:	±1%
Sudden Voltage Warp (100% Sudden Reduce):	+20%
Sudden Voltage Warp (Sudden Increase):	-15%
Voltage Stable Time (100% Sudden Reduce):	≤4S
Voltage Stable Time (Sudden Increase)	≤4S
Frequency Regulation, Stead State:	≤5% Adjustable
Frequency Waving:	≤0.5%
Sudden Frequency Warp (100% Sudden Reduce):	+10%
Sudden Frequency Warp (Sudden Increase):	-7%
Frequency Recovery Time (100% Sudden Reduce):	≤3S
Frequency Recovery Time (Sudden Increase):	≤3S
Noise Level:	117dB

Options

Engine	Fuel System	Control System
<ul style="list-style-type: none"> ● Heater 2KW & 4KW ● Battery Charger 3.5A & 7A 	<ul style="list-style-type: none"> ● Daily Fuel Tank ● Base Fuel Tank ● Water Separator ● Fuel Level Sensor 	<ul style="list-style-type: none"> ● Auto Control Panel ● Remote Control Panel ● Auto Transfer Switch (ATS) ● Paralleling System
Alternator	Others	Data
<ul style="list-style-type: none"> ● Anti Condensation Heater ● Permanent Magnet Generator (PMG) ● Drop CT (For Paralleling) 	<ul style="list-style-type: none"> ● Rainproof Type ● Soundproof Type ● Trailer Type 	<ul style="list-style-type: none"> ● Engine Parts Drawing List ● Spare Parts

Dimension & Weight

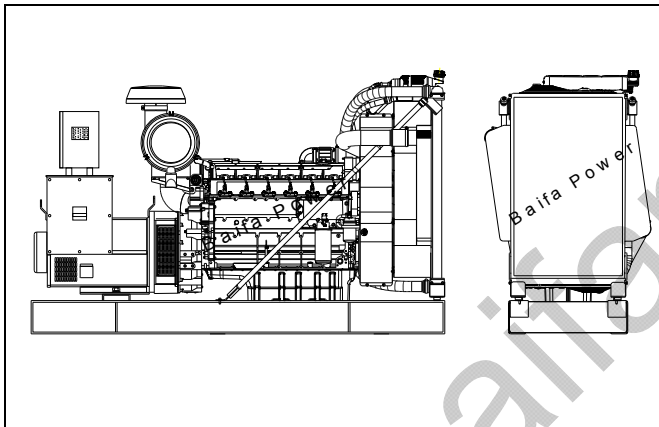

Standard Configuration (Open Type)

Overall Size: 2600 (mm) *1050 (mm) *1500 (mm)

Weight: 1600kg

With Base Fuel Tank

Overall Size: 2600 (mm) *1050 (mm) *1770 (mm)

Weight: 1800kg

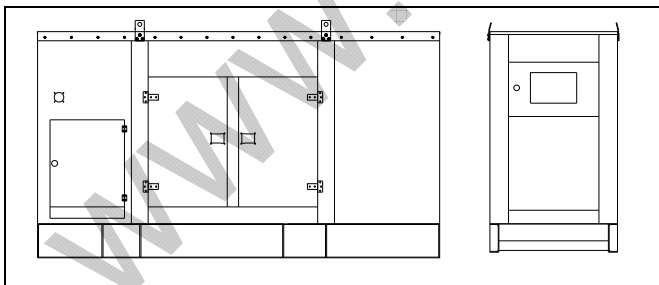

Soundproof Type

Overall Size: 3590 (mm) *1250 (mm) *2050 (mm)

Weight: 2950kg

Standard Control Panel



Baifa Standard Control Panel is the basic configuration for normal operation and usage, it is of some advantages such as easy to operate, various function and well protection. Operative buttons such as Turn On, Per-heat, Starting, Stop (Emergency Stop) on the panel. While malfunction occurs, control panel will stop the generator and also alarm with light or buzz.

Auto Module Control Panel



Auto Module Control Panel is the configuration for nobody on duty controlling generators. This kind of panel adopts auto module control system, with large LCD display to show the menu.

Features: MRS10-can receive remote output signal from ATS and realize auto start and stop of generators.

MRS16-can realize all functions of MRS10, add RS232 interface which can communicate with PC to realize remote operation.

AMF25-Auto Mains Failure controller, can realize all functions of MRS16, furthermore can detect ATS and control directly.

Auto Parallel Control Panel



Automatic Parallel Control Panel This new automatic parallel system adopts intelligent modules, inserted and folded installed, no need the peripheral relay and logic circuit. The main switch adopts electronic breaker or frame breaker, combined together with the generator, which is very reliable. One generator, one panel. The panel can be used both for singly and parallel. It is only need to parallel generator with such panel when the capability needs to be enlarged in the future.