

MODEL	BF-V165
Standby Power (50Hz)	132KW / 165KVA
Prime Power (50Hz)	120KW / 150KVA

### Standard Features

#### General Features:

- Engine (VOLVO TAD731GE)
- Radiator 55°C max, fans are driven by belt, with safety guard
- 24V charge alternator
- Alternator: single bearing alternator IP23, insulation class H/H
- Absorber
- Dry type air filter, fuel filter, oil filter, pre-filter
- Main line circuit breaker
- Standard control panel
- Oil drain pump
- Two 12V batteries, rack and cable
- Ripple flex exhaust pipe, exhaust siphon, flange, muffler
- User manual



PHOTO FOR REFERENCE ONLY

### Generator Ratings

Voltage	HZ	Phase	P.F (COS $\phi$ )	Standby Amps	Standby Ratings (KW/KVA)	Prime Ratings (KW/KVA)
440/254	50	3	0.8	217	132/165	120/150
415/240	50	3	0.8	230	132/165	120/150
400/230	50	3	0.8	238	132/165	120/150
380/220	50	3	0.8	251	132/165	120/150

Prime Power (PRP): Prime power is available for an unlimited number of annual hours in variable load application, in accordance with GB/T2820-97 (eqv ISO8528) ; A 10% overload capability is available for a period of 1 hour within a 12-hour period of operation.

Standby Power Rating (ESP): The standby power rating is applicable for supplying emergency power for the duration of a utility power interruption. No overload, utility parallel or negotiated outage operation capability is available at this rating.

### Sales Promises

Baifa Power provides a full line of brand new and high quality products. Each and every unit is strictly factory tested.

Warranty is according to our standard conditions: a, 15 months, counted on the day BAIFA sold to the first buyer; b, One year after installation; c, 1000 running hours (accumulated); subject to the earlier one.

Service and parts are available from Baifa Power or distributors in your location.

### ENGINE DATA

Manufacturer / Model:	VOLVO TAD731GE, 4-cycle
Air Intake System:	Turbo, Air/Air Cooling
Fuel System:	Directly Injection Fuel System, Bosch Pump
Cylinder Arrangement:	6 in line
Displacement:	7.15L
Bore and Stroke:	108*130 (mm)
Compression Ratio:	17.5
Rated RPM:	1500rpm
Max. Standby Power at Rated RPM:	148KW/201HP (with fan)
Governor Type:	Heinzman Mechanical Governor

#### Exhaust System

Exhaust Gas Flow:	30.2m <sup>3</sup> /min
Exhaust Temperature:	540°C
Max Back Pressure:	5kPa

#### Air Intake System

Max Intake Restriction:	3.5kPa
Burning Capacity:	10.65m <sup>3</sup> /min
Intake Flow:	150m <sup>3</sup> /min

#### Fuel System

100%(Prime Power) Load:	215 g/KWh
75%(Prime Power) Load:	216 g/KWh
50%(Prime Power) Load:	224 g/KWh
Total Fuel Flow:	360L/h

#### Oil System

Total Oil Capacity:	20L
Oil Consumption:	0.10L/h
Engine Oil Tank Capacity:	17L
Oil Pressure at Rated RPM:	480-520kPa

#### Cooling System

Total Coolant Capacity:	23.8L
Thermostat:	83-95°C
Max Water Temperature:	105°C

### ALTERNATOR SPECIFICATION

#### GENERAL DATA

Compliance with GB755, BS5000, VDE0530, NEMAMG1-22, IED34-1, CSA22.2 and AS1359 standards.

#### Alternator Data

Number of Phase:	3
Connecting Type:	3 Phase and 4 Wires, "Y" type connecting
Number of Bearing:	1
Power Factor:	0.8
Protection Grade:	IP23
Altitude:	≤1000m
Exciter Type:	Brushless, self-exciting
Insulation Class, Temperature Rise:	H/H
Telephone Influence Factor (TIF):	< 50
THF:	< 2%
Voltage Regulation, Steady State:	±1%
Alternator Capacity:	160KVA
Alternator Efficiencies:	92.3%
Air Cooling Flow:	0.514m <sup>3</sup> /s

### GENERATING SET DATA

Voltage Regulation:	±5%
Voltage Regulation, Stead State:	±1%
Sudden Voltage Warp (100% Sudden Reduce):	+25%
Sudden Voltage Warp (Sudden Increase):	-20%
Voltage Stable Time (100% Sudden Reduce):	≤6S
Voltage Stable Time (Sudden Increase)	≤6S
Frequency Regulation, Stead State:	±4%
Frequency Waving:	±1.5%
Sudden Frequency Warp (100% Sudden Reduce):	+12%
Sudden Frequency Warp (Sudden Increase):	-10%
Frequency Recovery Time (100% Sudden Reduce):	≤5S
Frequency Recovery Time (Sudden Increase):	≤5S
Noise Level:	112dB

### Options

Engine	Fuel System	Control System
<ul style="list-style-type: none"> <li>● Heater 2KW &amp; 4KW</li> <li>● Battery Charger 3.5A &amp; 7A</li> </ul>	<ul style="list-style-type: none"> <li>● Daily Fuel Tank</li> <li>● Base Fuel Tank</li> <li>● Water Separator</li> <li>● Fuel Level Sensor</li> </ul>	<ul style="list-style-type: none"> <li>● Auto Control Panel</li> <li>● Remote Control Panel</li> <li>● Auto Transfer Switch (ATS)</li> <li>● Paralleling System</li> </ul>
Alternator	Others	Data
<ul style="list-style-type: none"> <li>● Anti Condensation Heater</li> <li>● Permanent Magnet Generator (PMG)</li> <li>● Drop CT (For Paralleling)</li> </ul>	<ul style="list-style-type: none"> <li>● Rainproof Type</li> <li>● Soundproof Type</li> <li>● Trailer Type</li> </ul>	<ul style="list-style-type: none"> <li>● Engine Parts Drawing List</li> <li>● Spare Parts</li> </ul>

### Dimension & Weight

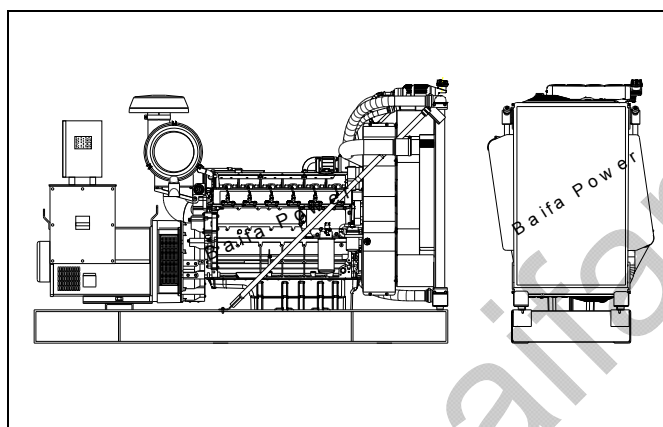

#### Standard Configuration (Open Type)

Overall Size: 2400 (mm) \* 870 (mm) \* 1450 (mm)

Weight: 1560kg

#### With Base Fuel Tank

Overall Size: 2400 (mm) \* 920 (mm) \* 1550 (mm)

Weight: 1760kg

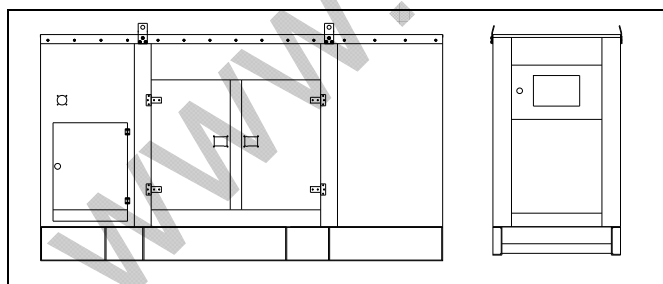

#### Soundproof Type

Overall Size: 3230 (mm) \* 1170 (mm) \* 1800 (mm)

Weight: 2400kg

### Standard Control Panel

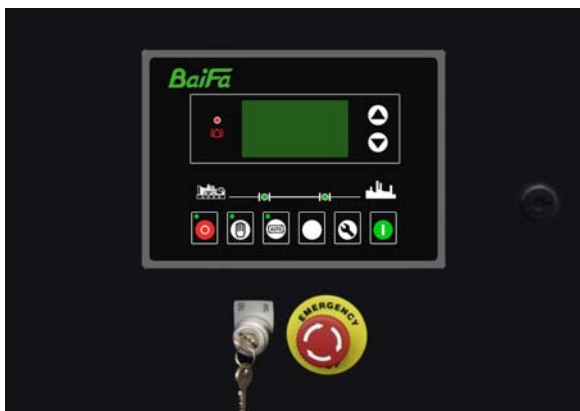

**Baifa Standard Control Panel** uses micro processing technique integrating digital, intelligent and network techniques which can carry out functions including auto start/stop, data measure, alarming and communication to PC with RS485 port. The controller uses LCD display, optional Chinese and English display interface with operation easy and reliable. It can be widely used in all types of generator automatic control system for compact structure, advanced circuits, simple connections and high reliability.

### Auto Module Control Panel



**Auto Module Control Panel** is the configuration for nobody on duty controlling generators. This kind of panel adopts auto module control system, with large LCD display to show the menu.

Features: MRS10-can receive remote output signal from ATS and realize auto start and stop of generators.

MRS16-can realize all functions of MRS10, add RS232 interface which can communicate with PC to realize remote operation.

AMF25-Auto Mains Failure controller, can realize all functions of MRS16, furthermore can detect ATS and control directly.

### Auto Parallel Control Panel



**Automatic Parallel Control Panel** This new automatic parallel system adopts intelligent modules, inserted and folded installed, no need the peripheral relay and logic circuit. The main switch adopts electronic breaker or frame breaker, combined together with the generator, which is very reliable. One generator, one panel. The panel can be used both for singly and parallel. It is only need to parallel generator with such panel when the capability needs to be enlarged in the future.