

MODEL	BF-P1875
Standby Power (50Hz)	1500KW /1875KVA
Prime Power (50Hz)	1364KW /1705KVA

Standard Features

General Features:

- Engine (Perkins 4012-46 TAG3A)
- Radiator 40°C max, fans are driven by belt, with safety guard
- 24V charge alternator
- Alternator: single bearing alternator IP23, insulation class H/H
- Absorber
- Dry type air filter, fuel filter, oil filter, coolant filter
- Main line circuit breaker
- Standard control panel
- batteries, rack and cable
- Ripple flex exhaust pipe, exhaust siphone, flange, muffler
- User manual



PHOTO FOR REFERENCE ONLY

Generator Ratings

Voltage	HZ	Phase	P.F (COS ϕ)	Standby Amps	Standby Ratings (KW/KVA)	Prime Ratings (KW/KVA)
440/254	50	3	0.8	2460	1500/1875	1364/1705
415/240	50	3	0.8	2608	1500/1875	1364/1705
400/230	50	3	0.8	2706	1500/1875	1364/1705
380/220	50	3	0.8	2848	1500/1875	1364/1705

Prime Power (PRP): Prime power is available for an unlimited number of annual hours in variable load application, in accordance with GB/T2820-97 (eqvISO8528) ; A 10% overload capability is available for a period of 1 hour within a 12-hour period of operation.

Standby Power Rating (ESP): The standby power rating is applicable for supplying emergency power for the duration of a utility power interruption. No overload, utility parallel or negotiated outage operation capability is available at this rating.

Sales Promises

Baifa Power provides a full line of brand new and high quality products. Each and every unit is strictly factory tested.

Warranty is according to our standard conditions: 12 months or 1,000 running hours, subject to the earlier one.

Service and parts are available from Baifa Power or distributors in your location.

ENGINE DATA

Manufacturer / Model:	Perkins 4012-46 TAG3A, 4-cycle
Air Intake System:	Turbo, Air/Air cooling
Fuel Injection System:	Direct Injection
Cylinder Arrangement:	12 in "V"
Displacement:	45.842L
Bore and Stroke:	160×190 (mm)
Compression Ratio:	13.0
Rated RPM:	1500rpm
Max. Standby Power at Rated RPM:	1643KW/2235HP
Governor Type:	Electronic

Exhaust System

Exhaust Gas Flow(after turbo):	350m ³ /min
Exhaust Temperature:	480°C
Max Back Pressure:	5kPa

Air Intake System

Max Intake Restriction:	4kPa
Consumption:	135m ³ /min
Air Flow:	1920m ³ /min

Fuel System

100%(Prime Power) Load:	208 g/Kwh
75%(Prime Power) Load:	206 g/Kwh
50%(Prime Power) Load:	202 g/Kwh
100%(Prime Power) Load:	347L/h

Oil System

Oil Consumption:	0.51g/KW/hr
Engine Oil Tank Capacity:	159L
Min Oil Pressure at Rated RPM:	340kPa

Cooling System

Total Coolant Capacity:	212L
Thermostat:	71-85°C
Max Water Temperature:	98°C

ALTERNATOR SPECIFICATION

GENERAL DATA

Compliance with GB755, BS5000, VDE0530, NEMAMG1-22, IED34-1, CSA22.2 and AS1359 standards.

Alternator Data

Number of Phase:	3
Connecting Type:	3 Phase and 4 Wires, "Y" type connecting
Number of Bearing:	1
Power Factor:	0.8
Protection Grade:	IP23
Altitude:	≤1000m
Exciter Type:	Brushless, self-exciting
Insulation Class, Temperature Rise:	H/H
Telephone Influence Factor (TIF):	<50
THF:	<2%
Voltage Regulation, Steady State:	±1%
Alternator Capacity:	1900KVA
Alternator Efficiencies:	96.2%
Air Cooling Flow:	2.69m ³ /s

GENERATING SET DATA

Voltage Regulation:	±5%
Voltage Regulation, Stead State:	±1%
Sudden Voltage Warp (100% Sudden Reduce):	≤+25%
Sudden Voltage Warp (Sudden Increase):	≤-20%
Voltage Stable Time (100% Sudden Reduce):	≤6S
Voltage Stable Time (Sudden Increase):	≤6S
Frequency Regulation, Stead State:	≤5%
Frequency Waving:	≤1%
Sudden Frequency Warp (100% Sudden Reduce):	≤+12%
Sudden Frequency Warp (Sudden Increase):	≤-10%
Frequency Recovery Time (100% Sudden Reduce):	≤5S
Frequency Recovery Time (Sudden Increase):	≤5S

Options

Engine	Fuel System	Control System
<ul style="list-style-type: none"> ● Heater ● Battery Charger 	<ul style="list-style-type: none"> ● Daily Fuel Tank ● Base Fuel Tank ● Water Separator 	<ul style="list-style-type: none"> ● Auto Control Panel ● Remote Control Panel ● Auto Transfer Switch (ATS) Control Panel ● Paralleling System ● Electricity Output Cabinet
Alternator	Others	Data
<ul style="list-style-type: none"> ● Anti Condensation Heater ● Permanent Magnet Generator (PMG) ● Drop CT (For Paralleling) 	<ul style="list-style-type: none"> ● Rainproof Type ● Soundproof Type ● Trailer Type 	<ul style="list-style-type: none"> ● Engine Parts Drawing List ● Spare Parts

Dimension & Weight

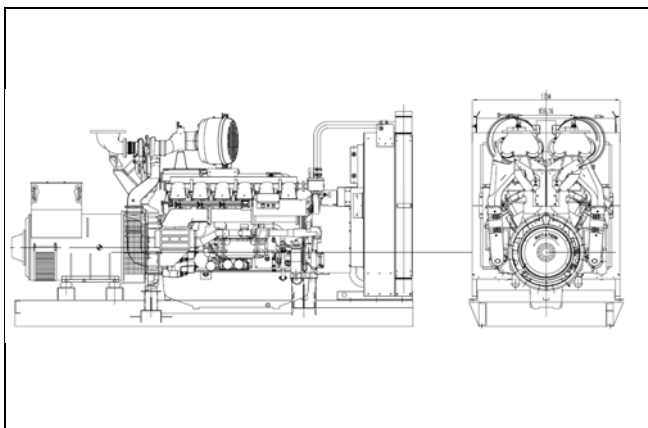

Standard Configuration (Open Type)

Overall Size: 5100 (mm) × 2170 (mm) × 2850 (mm)
Weight: 13300kg

With Base Fuel Tank

Overall Size:
Weight:

Auto Module Control Panel



Auto Module Control Panel is the configuration for nobody on duty controlling generators. This kind of panel adopts auto module control system, with large LCD display to show the menu.

Features: MRS10-can receive remote output signal from ATS and realize auto start and stop of generators.

MRS16-can realize all functions of MRS10, add RS232 interface which can communicate with PC to realize remote operation.

AMF25-Auto Mains Failure controller, can realize all functions of MRS16, furthermore can detect ATS and control directly.

Auto Parallel Control Panel



Automatic Parallel Control Panel This new automatic parallel system adopts intelligent modules, inserted and folded installed, no need the peripheral relay and logic circuit. The main switch adopts electronic breaker or frame breaker, combined together with the generator, which is very reliable. One generator, one panel. The panel can be used both for singly and parallel. It is only need to parallel generator with such panel when the capability needs to be enlarged in the future.