

MODEL	BF-P10
Standby Power (50Hz)	8KW /10KVA
Prime Power (50Hz)	7.2KW /9KVA

Standard Features

General Features:

- Engine (Perkins 403D-11G)
- Radiator 50°C max, fans are driven by belt, with safety guard
- 24V charge alternator
- Alternator: single bearing alternator IP23, insulation class H/H
- Absorber
- Dry type air filter, fuel filter, oil filter, coolant filter
- Main line circuit breaker
- Standard control panel
- batteries, rack and cable
- Ripple flex exhaust pipe, exhaust siphone, flange, muffler
- User manual



PHOTO FOR REFERENCE ONLY

Generator Ratings

Voltage	HZ	Phase	P.F ($\cos \phi$)	Standby Amps	Standby Ratings (KW/KVA)	Prime Ratings (KW/KVA)
440/254	50	3	0.8	13.1	8/10	7.2/9
415/240	50	3	0.8	13.9	8/10	7.2/9
400/230	50	3	0.8	14.4	8/10	7.2/9
380/220	50	3	0.8	15.1	8/10	7.2/9

Prime Power (PRP): Prime power is available for an unlimited number of annual hours in variable load application, in accordance with GB/T2820-97 (equivISO8528) ; A 10% overload capability is available for a period of 1 hour within a 12-hour period of operation.

Standby Power Rating (ESP): The standby power rating is applicable for supplying emergency power for the duration of a utility power interruption. No overload, utility parallel or negotiated outage operation capability is available at this rating.

Sales Promises

Baifa Power provides a full line of brand new and high quality products. Each and every unit is strictly factory tested.

Warranty is according to our standard conditions: 12 months or 1,000 running hours, subject to the earlier one.

Service and parts are available from Baifa Power or distributors in your location.

ENGINE DATA

Manufacturer / Model:	Perkins 403D-11G, 4-cycle
Air Intake System:	Naturally aspirated
Fuel Injection System:	Direct Injection
Cylinder Arrangement:	3 in line
Displacement:	1.131L
Bore and Stroke:	77×81 (mm)
Compression Ratio:	23:1
Rated RPM:	1500rpm
Max. Standby Power at Rated RPM:	9.5KW/12.9HP
Governor Type:	Mechanical

Exhaust System

Exhaust Gas Flow(after turbo):	1.8m ³ /min
Exhaust Temperature:	420°C
Max Back Pressure:	10.2kPa

Air Intake System

Max Intake Restriction:	6.4kPa
Consumption:	0.7m ³ /min
Air Flow:	40.2m ³ /min

Fuel System

100%(Prime Power) Load:	252 g/Kwh
75%(Prime Power) Load:	258 g/Kwh
50%(Prime Power) Load:	286 g/Kwh
100%(Prime Power) Load:	2.7L/h

Oil System

Oil Consumption:	4g/KW hr
Engine Oil Tank Capacity:	4.9L
Min Oil Pressure at Rated RPM:	304-500kPa

Cooling System

Total Coolant Capacity:	5.2L
Thermostat:	75-87°C
Max top tank Temperature:	112°C

ALTERNATOR SPECIFICATION

GENERAL DATA

Compliance with GB755, BS5000, VDE0530, NEMAMG1-22, IED34-1, CSA22.2 and AS1359 standards.

Alternator Data

Number of Phase:	3
Connecting Type:	3 Phase and 4 Wires, "Y" type connecting
Number of Bearing:	1
Power Factor:	0.8
Protection Grade:	IP23
Altitude:	≤1000m
Exciter Type:	Brushless, self-exciting
Insulation Class, Temperature Rise:	H/H
Telephone Influence Factor (TIF):	<50
THF:	<2%
Voltage Regulation, Steady State:	±1%
Alternator Capacity:	10KVA
Alternator Efficiencies:	80.5%
Air Cooling Flow:	0.09 m ³ /s

GENERATING SET DATA

Voltage Regulation:	±5%
Voltage Regulation, Stead State:	±1%
Sudden Voltage Warp (100% Sudden Reduce):	≤+25%
Sudden Voltage Warp (Sudden Increase):	≤-20%
Voltage Stable Time (100% Sudden Reduce):	≤6S
Voltage Stable Time (Sudden Increase):	≤6S
Frequency Regulation, Stead State:	≤5%
Frequency Waving:	≤1%
Sudden Frequency Warp (100% Sudden Reduce):	≤+12%
Sudden Frequency Warp (Sudden Increase):	≤-10%
Frequency Recovery Time (100% Sudden Reduce):	≤5S
Frequency Recovery Time (Sudden Increase):	≤5S

Options

Engine	Fuel System	Control System
<ul style="list-style-type: none"> ● Heater ● Battery Charger 	<ul style="list-style-type: none"> ● Daily Fuel Tank ● Base Fuel Tank ● Water Separator 	<ul style="list-style-type: none"> ● Auto Control Panel ● Remote Control Panel ● Auto Transfer Switch (ATS) Control Panel ● Paralleling System ● Electricity Output Cabinet
Alternator	Others	Data
<ul style="list-style-type: none"> ● Anti Condensation Heater ● Permanent Magnet Generator (PMG) ● Drop CT (For Paralleling) 	<ul style="list-style-type: none"> ● Rainproof Type ● Soundproof Type ● Trailer Type 	<ul style="list-style-type: none"> ● Engine Parts Drawing List ● Spare Parts

Dimension & Weight

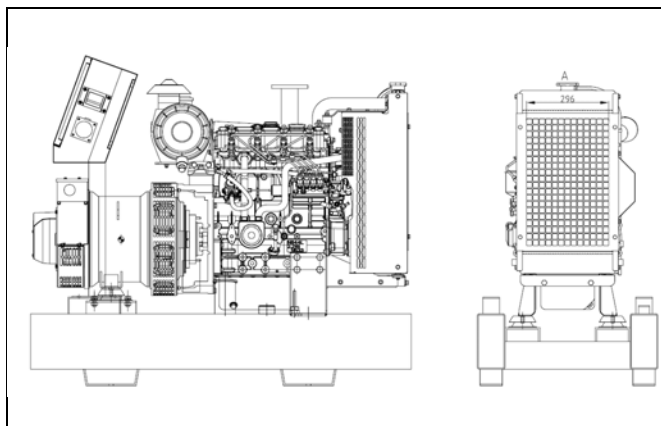

Standard Configuration (Open Type)

Overall Size: 1150 (mm) × 500 (mm) × 1100 (mm)
Weight: 280kg

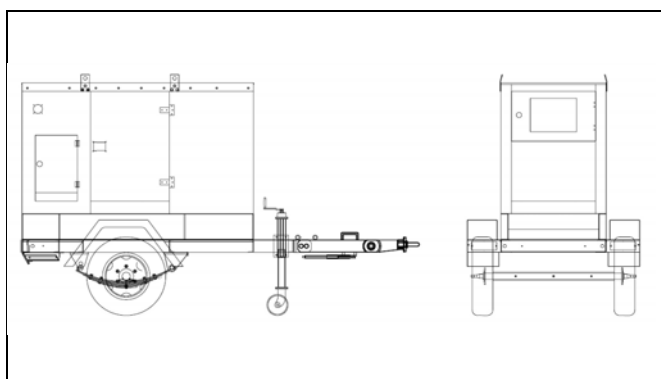

Soundproof Type

Overall Size: 1710 (mm) × 880 (mm) × 1350 (mm)
Weight: 680kg

Trailer Type

Overall Size:
Weight:

Standard Control Panel



Baifa Standard Control Panel uses micro processing technique integrating digital, intelligent and network techniques which can carry out functions including auto start/stop, data measure, alarming. The controller uses LCD display, optional Chinese and English display interface with operation easy and reliable. It can be widely used in all types of generator automatic control system for compact structure, advanced circuits, simple connections and high reliability

Auto Module Control Panel



Auto Module Control Panel is the configuration for nobody on duty controlling generators. This kind of panel adopts auto module control system, with large LCD display to show the menu.

Features: MRS10-can receive remote output signal from ATS and realize auto start and stop of generators.

MRS16-can realize all functions of MRS10, add RS232 interface which can communicate with PC to realize remote operation.

AMF25-Auto Mains Failure controller, can realize all functions of MRS16, furthermore can detect ATS and control directly.