

MODEL	BF-M1375
Standby Power (50Hz)	1100KW / 1375KVA
Prime Power (50Hz)	1000KW / 1250KVA

Standard Features

General Features:

- Engine (MTU 12V4000G21R)
- Radiator 40°C max, fans are driven by motor, with safety guard
- 24V charge alternator
- Alternator: single bearing alternator IP23, insulation class H/H
- Absorber
- Dry type air filter, fuel filter, oil filter
- Permanent Magnet Generator (PMG)
- Standard control panel
- Four 12V batteries, rack and cable
- Ripple flex exhaust pipe, exhaust siphon, flange, muffler
- User manual



PHOTO FOR REFERENCE ONLY

Generator Ratings

Voltage	HZ	Phase	P.F ($\cos \phi$)	Standby Amps	Standby Ratings (KW/KVA)	Prime Ratings (KW/KVA)
440/254	50	3	0.8	1804	1100/1375	1000/1250
415/240	50	3	0.8	1913	1100/1375	1000/1250
400/230	50	3	0.8	1985	1100/1375	1000/1250
380/220	50	3	0.8	2089	1100/1375	1000/1250

Prime Power (PRP): Prime power is available for an unlimited number of annual hours in variable load application, in accordance with GB/T2820-97 (eqv ISO8528) ; A 10% overload capability is available for a period of 1 hour within a 12-hour period of operation.

Standby Power Rating (ESP): The standby power rating is applicable for supplying emergency power for the duration of a utility power interruption. No overload, utility parallel or negotiated outage operation capability is available at this rating.

Sales Promises

Baifa Power provides a full line of brand new and high quality products. Each and every unit is strictly factory tested.

Warranty is according to our standard conditions: a, 15 months, counted on the day BAIFA sold to the first buyer; b, One year after installation; c, 1000 running hours (accumulated); subject to the earlier one.

Service and parts are available from Baifa Power or distributors in your location.

ENGINE DATA

Manufacturer / Model:	MTU/12V4000G21R
Air Intake System:	Turbo, Water/Air Cooling
Fuel System:	Electronic Fuel Injection System
Cylinder Arrangement:	12 in "V"
Displacement:	48.7L
Bore and Stroke:	165*190 (mm)
Compression Ratio:	15.5
Rated RPM:	1500rpm
Max. Standby Power at Rated RPM:	1212KW (without fan)
Governor Type:	ADEC

Exhaust System

Exhaust Gas Flow:	228m ³ /min
Exhaust Temperature:	495°C
Max Back Pressure:	5.1kPa

Air Intake System

Max Intake Restriction:	5kPa
Burning Capacity:	96m ³ /min

Fuel System

100%(Prime Power) Load:	199 g/kwh
75%(Prime Power) Load:	203 g/kwh
50%(Prime Power) Load:	208 g/kwh
Total Fuel Flow:	1020L/h

Oil System

Total Oil Capacity:	260L
Oil Consumption:	0.5% Fuel Consumption
Engine Oil Tank Capacity:	200L
Oil Pressure at Rated RPM:	500-600kPa

Cooling System

Engine Coolant Capacity:	160L
Thermostat:	79°C
Max Water Temperature:	99°C

ALTERNATOR SPECIFICATION

GENERAL DATA

Compliance with GB755, BS5000, VDE0530, NEMAMG1-22, IED34-1, CSA22.2 and AS1359 standards.

Alternator Data

Number of Phase:	3
Connecting Type:	3 Phase and 4 Wires, "Y" type connecting
Number of Bearing:	1
Power Factor:	0.8
Protection Grade:	IP23
Altitude:	≤1000m
Exciter Type:	Brushless, self-exciting
Insulation Class, Temperature Rise:	H/H
Telephone Influence Factor (TIF):	<50
THF:	<2%
Voltage Regulation, Steady State:	±1%
Alternator Capacity:	1250KVA
Alternator Efficiencies:	95.1%
Air Cooling Flow:	1.8m ³ /s

GENERATING SET DATA

Voltage Regulation:	±5%
Voltage Regulation, Stead State:	±1%
Sudden Voltage Warp (100% Sudden Reduce):	+20%
Sudden Voltage Warp (Sudden Increase):	-15%
Voltage Stable Time (100% Sudden Reduce):	≤4S
Voltage Stable Time (Sudden Increase)	≤4S
Frequency Regulation, Stead State:	≤5% adjustable
Frequency Waving:	≤0.5%
Sudden Frequency Warp (100% Sudden Reduce):	+10%
Sudden Frequency Warp (Sudden Increase):	-7%
Frequency Recovery Time (100% Sudden Reduce):	≤3S
Frequency Recovery Time (Sudden Increase):	≤3S
Noise Level:	115dB
Emission Level:	TA-Luft

Options

Engine	Fuel System	Control System
<ul style="list-style-type: none"> ● Oil Drain Valve 	<ul style="list-style-type: none"> ● Daily Fuel Tank ● Base Fuel Tank ● Water Separator ● Fuel Level Sensor 	<ul style="list-style-type: none"> ● Remote Control Panel ● Main line circuit breaker ● Paralleling System ● Electricity Output Cabinet
Alternator	Others	Data
<ul style="list-style-type: none"> ● Anti Condensation Heater ● Drop CT (For Paralleling) 	<ul style="list-style-type: none"> ● Rainproof Type ● Soundproof Type ● Container Type 	<ul style="list-style-type: none"> ● Spare Parts

Dimension & Weight

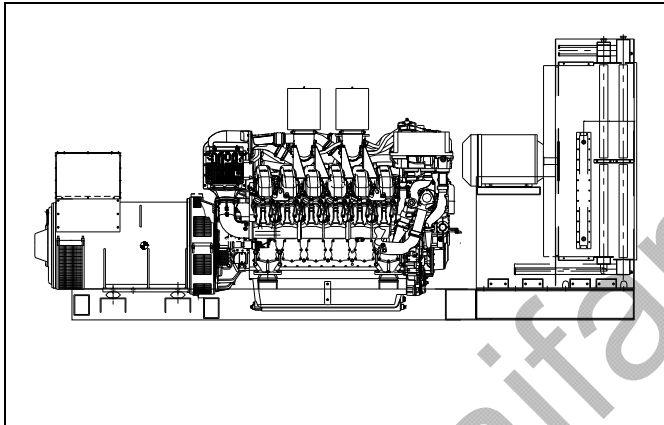

Standard Configuration (Without Radiator)

Overall Size: 4200 (mm) × 1900 (mm) × 2300 (mm)

Weight: 10500kg

Standard Configuration (With Radiator)

Overall Size: 6150 (mm) × 2150 (mm) × 2400 (mm)

Weight: 11500kg

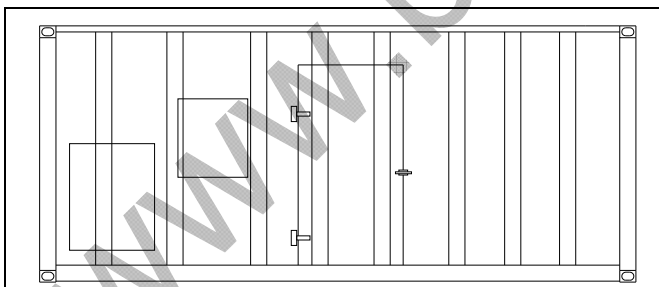

Soundproof Type

Overall Size: Standard 40'ft high container

Weight: 18000kg

Auto Module Control Panel



Auto Module Control Panel is the configuration for nobody on duty controlling generators. This kind of panel adopts auto module control system, with large LCD display to show the menu.

Features: MRS10-can receive remote output signal from ATS and realize auto start and stop of generators.

MRS16-can realize all functions of MRS10, add RS232 interface which can communicate with PC to realize remote operation.

AMF25-Auto Mains Failure controller, can realize all functions of MRS16, furthermore can detect ATS and control directly.

Auto Parallel Control Panel



Automatic Parallel Control Panel This new automatic parallel system adopts intelligent modules, inserted and folded installed, no need the peripheral relay and logic circuit. The main switch adopts electronic breaker or frame breaker, combined together with the generator, which is very reliable. One generator, one panel. The panel can be used both for singly and parallel. It is only need to parallel generator with such panel when the capability needs to be enlarged in the future.